



2 STORY

EastBanc

3025 M ST,NW

› 2,830 SF AVAILABLE WITH ALL GLASS M STREET FRONTAGE

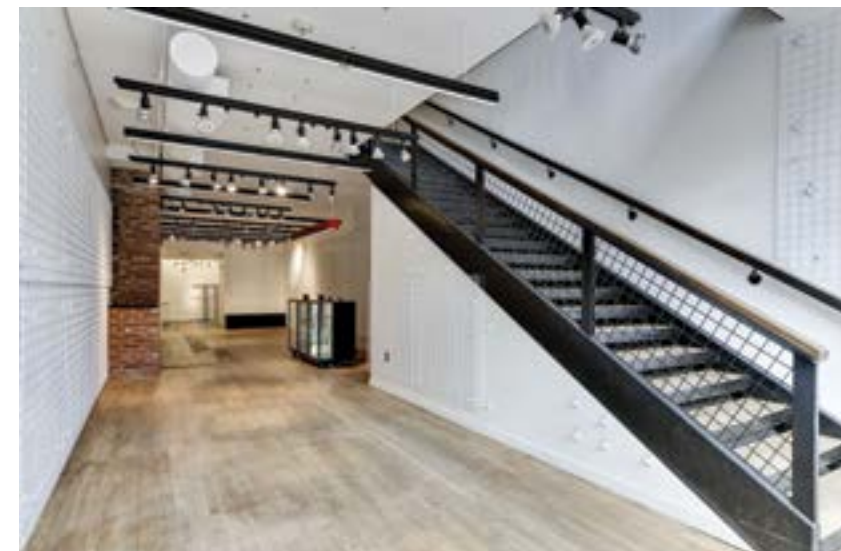

**ADDITIONAL 530 SF OF BASEMENT
RETAIL SPACE AVAILABLE**

3025 M ST, NW



2 FLOORS WITH BASEMENT STORAGE



BASEMENT

530 SF

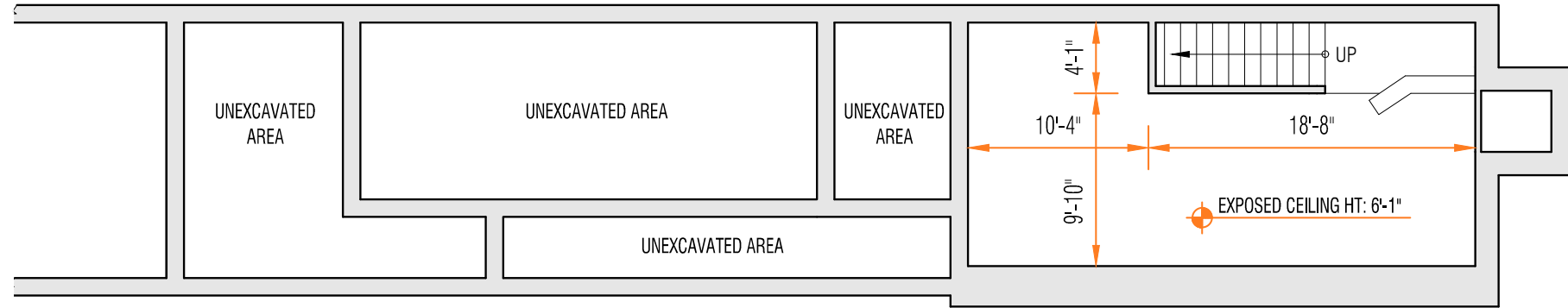

FIRST FLOOR

1,200 SF

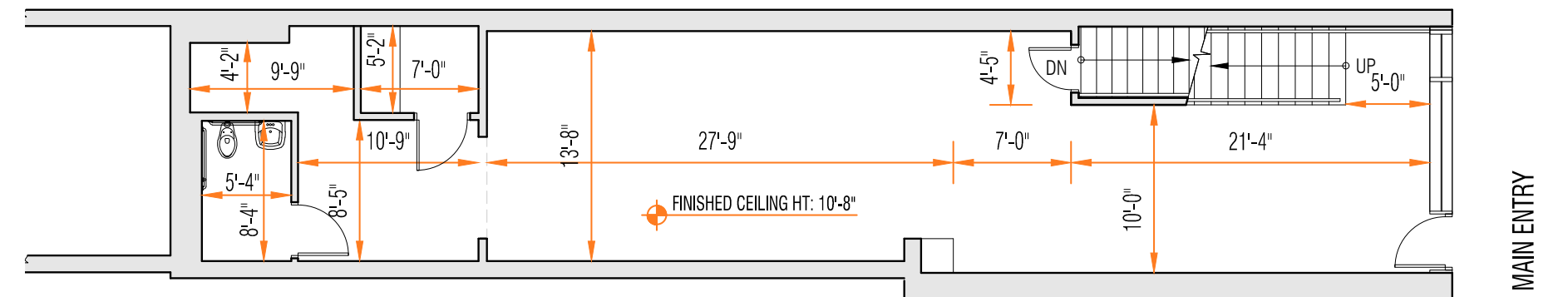

3025 M ST NW
WASHINGTON, D.C.

3025 M ST NW
WASHINGTON, D.C.

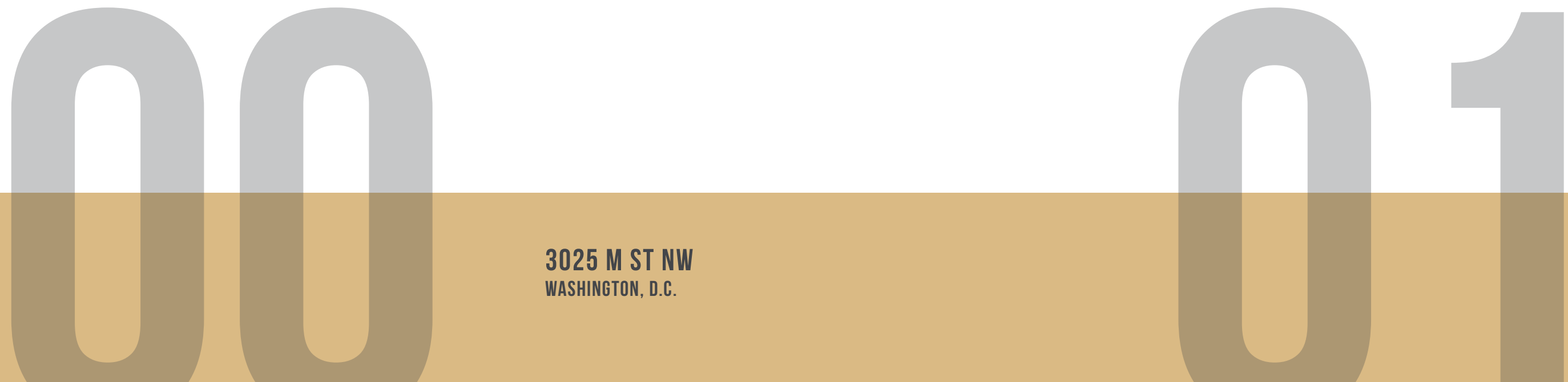

SECOND FLOOR

1,100 SF

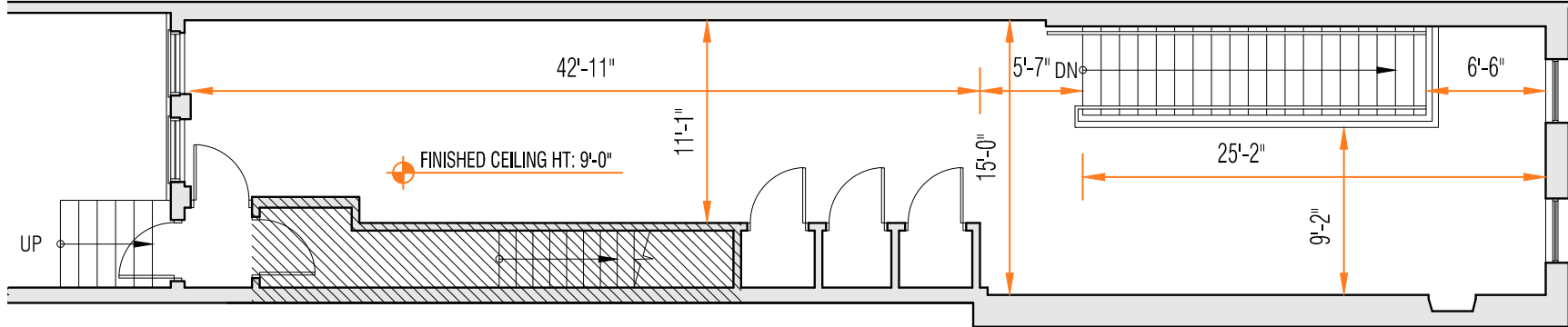

SUMMARY

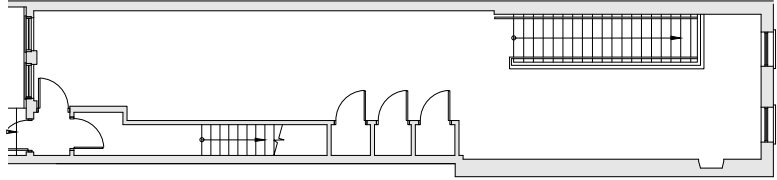

SECOND FLOOR

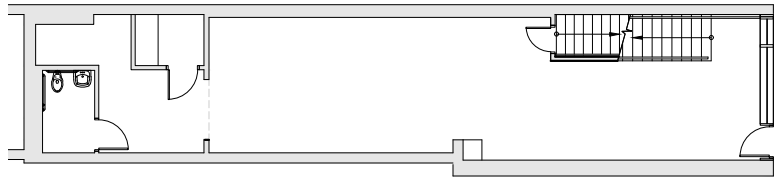

FIRST FLOOR

3025 M ST NW
WASHINGTON, D.C.





BLUE - MANAGED BY EAST BANK

GEORGETOWN

OVER **800,000**
NEARBY RESIDENTS

AVERAGE AREA INCOME OVER
\$110,000

35
AVERAGE AGE



OVER **70%**
COLLEGE EDUCATED

50,000
STUDENTS IN THE AREA

OVER **600,000**
AVERAGE MONTHLY PEDES-
TRIANS

EastBanc

BARRY GREENBERG
(202) 944-2142

bgreenberg@eastbanc.com

3223 Prospect Street NW
Washington, DC 20007

eastbanc.com